

Evaluation of a Wake-up Wireless Module with Bloom-Filter-Based ID Matching

Shigemi ISHIDA, Takahiro TAKIGUCHI, Shunsuke SARUWATARI,
Masateru MINAMI and Hiroyuki MORIKAWA

Morikawa Laboratory, RCAST, The University of Tokyo, Japan

Email: {ishida, takiguchi, saru, minami, mori}@mlab.t.u-tokyo.ac.jp

Abstract—We present a wake-up wireless communication system, which can drastically reduce idle listening energy for long idle listening applications by using a wake-up wireless module. We consider *chance encounter communication*, which is communication during opportunistic encounters, as a long idle listening application. There are three requirements for applying the wake-up system to chance encounter communication: a group selective wake-up, a multiple group support, and small circuit size. In order to achieve these three requirements, we introduce Bloom-filter-based ID matching to the wake-up wireless module.

The present paper describes the design of the wake-up module using a Bloom-filter-based ID matching mechanism. We evaluate the proposed module by performing circuit-level simulations. The simulation results show that the proposed system can reduce listening power by a factor of 1,000 to 10,000 compared to conventional Wi-Fi modules.

I. INTRODUCTION

Since excessive power consumption is a major problem in wireless communication, it is important to reduce power consumption related to wireless communication. The reduction of wireless communication power consumption is also important in order to realize an energy-efficient communication system as well as to extend application fields of wireless communication.

A listening state of radio modules consumes as much power as a receiving state. The reduction of the idle listening power consumption is important for long idle listening applications. Wi-Fi access points in a home network, for example, spend a great deal of time in idle listening compared to communication because there are a relatively small number of Wi-Fi devices in the home network. For such long idle listening applications, the most wireless communication energy is wasted in idle listening.

Previous studies have reported hardware improvements and various access control technologies to reduce the energy waste in idle listening. Although hardware improvements are applicable to all systems, the resulting power reduction is often insufficient. For example, a 2.4-GHz IEEE 802.15.4 and a 868/915 MHz transceiver, which consume as much as 30 mW and 2 mW, respectively, have been reported [1][2]. Access control technologies can sometimes considerably reduce the amount of the wasted energy [3][4][5]. However, access control technologies have trade-offs between communication latency and energy efficiency. A communication latency increases as the idle listening power decreases. The access control technologies are not suitable for long idle listening applications because these applications require a small latency compared to the long idle listening duration.

We propose a wake-up wireless communication system, which can drastically reduce the energy wasted in idle listening. The wake-up wireless communication system consists of two radio modules: a data communication module and a wake-up module. The data communication module is a general radio module, such as Wi-Fi, Bluetooth, or ZigBee. The wake-up module listens for wake-up packets transmitted prior to communication by transmitters and wakes the data communication module when necessary. The wake-up module consumes only several dozen microwatts in idle listening because of its limited function. Using the low-power wake-up module enables the data communication module to turn off during idle listening.

We consider applying the proposed wake-up system to one of the long idle listening applications: *chance encounter communication*, which is communication between two or more nodes with one another during infrequent, opportunistic encounters [6]. In chance encounter communication, transmitters have no information about target nodes before communication with the targets. Nevertheless, it is necessary to specify wake-up target nodes in the wake-up system.

In view of chance encounter communication, we propose a wake-up wireless communication system with group-based ID matching, which uses a Bloom filter [7]. ID matching is a mechanism that determines whether to wake the data communication module based on a destination node ID. The main contributions of the present paper are (1) the proposal of a wake-up wireless communication system with a group-based addressing capability, which can effectively reduce idle listening power consumption for long idle listening applications; (2) application of a Bloom filter to the group-based ID matching mechanism, which meets three requirements for chance encounter communication: group selectivity, a multiple group support, and small circuit size.

The remainder of the present paper is organized as follows. Section II describes a wake-up wireless communication system and the requirements of ID matching for chance encounter communication. In Section III, we propose a Bloom-filter-based ID matching mechanism, which can meet the three above-mentioned requirements. Section IV describes the circuit and the chip layout design of the proposed wake-up wireless module. In Section V, we evaluate the wake-up wireless module by performing circuit-level simulations and show that the proposed system can drastically reduce listening power consumption. Finally, Section VI concludes the paper.

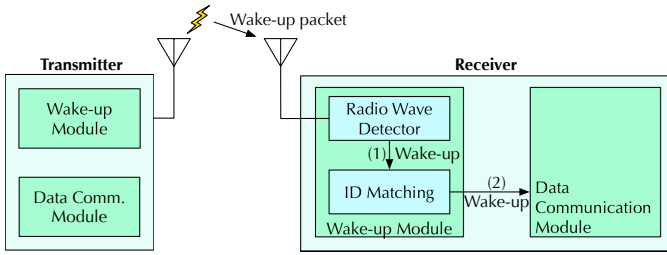

Fig. 1. Overview of a wake-up wireless communication system.

II. WAKE-UP WIRELESS COMMUNICATION SYSTEM

A. Overview

Figure 1 shows an overview of a wake-up wireless communication system. The wake-up wireless communication system consists of two radio modules: a data communication module and a wake-up module. The data communication module is a general purpose radio module, such as Wi-Fi, Bluetooth, or ZigBee. The wake-up module consists of a radio wave detector and an ID matching circuit. The radio wave detector is designed only to detect radio waves and therefore consumes only several dozen microwatts, whereas the data communication module consumes up to several hundred milliwatts. The ID matching circuit receives a wake-up packet and determines whether to wake the data communication module based on a destination ID derived from the wake-up packet. We use the ID matching circuit in order to avoid unnecessary wake-ups, which effectively reduce energy wasted in idle listening.

In the wake-up wireless communication system, only the radio wave detector is activated in idle listening, and therefore the system can realize low-power listening. The data communication module and the ID matching circuit are made to enter a sleep state in idle listening and are activated when necessary. A transmitter transmits a wake-up packet to initiate communication. When detecting radio waves, the radio wave detector wakes the ID matching circuit, and the ID matching circuit then receives the wake-up packet.

The ID matching circuit may be woken by mistake because the radio wave detector detects all radio waves at the wake-up channel frequency. In this case, the ID matching circuit receives no wake-up packet and goes into sleep state. The wake-up module goes back to idle listening in which only the radio wave detector is activated.

When the ID matching circuit receives a wake-up packet, the ID matching circuit checks a destination ID derived from the wake-up packet. If the destination ID matches the ID of the wake-up module, the ID matching circuit wakes the data communication module and then goes into the sleep state. If the IDs do not match, the ID matching circuit goes into the sleep state immediately.

When the data communication module is woken, the data communication module starts communication with the transmitter. After the communication has been completed, the data communication module reenters the sleep state.

B. Requirements of ID matching

We consider applying the proposed wake-up system to chance encounter communication, which is *in-the-moment* communication during opportunistic encounters: two nodes

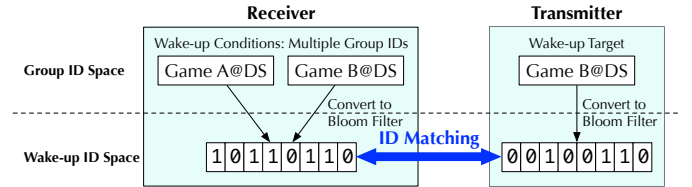

Fig. 2. Overview of ID matching.

encounter each other, communicate, and go their separate ways. One example of chance encounter communication is to exchange game information between handheld game consoles. In order to apply the proposed wake-up system to chance encounter communication, there are three ID matching requirements: group selectivity, a multiple group support, and small circuit size.

The first requirement is group selectivity. In chance encounter communication, a transmitter node cannot derive target node IDs prior to communication. The transmitter cannot determine the existence of other nodes. Although the transmitter can wake all of the nodes around itself, a considerable amount of energy will be wasted in the nodes that do not need to communicate with the transmitter. We therefore specify a group of nodes as wake-up targets based on target node functions. Considering chance encounter communication between handheld game consoles, for example, the game consoles are grouped by supporting games. The game consoles need to specify and wake the communication target console based on a supporting game: *the game console that supports 'Game A.'*

The second requirement is a multiple group support. A wireless communication device has many functions and therefore belongs to multiple groups in our grouping scheme. Considering again chance encounter communication between handheld game consoles, for example, a game console may have multiple games: *'Game A' and 'Game B.'* In this case, the console must wake up when the transmitter specifies both *the game console that has 'Game A,'* and *the game console that has 'Game B.'*

Finally, the third requirement is small circuit size. Since a big circuit is usually costly, a small circuit is required for low-cost fabrication.

III. BLOOM-FILTER-BASED ID MATCHING

As shown in Fig. 1, an ID matching circuit is part of a wake-up module. The ID matching circuit is woken by a radio wave detector and performs ID matching. According to the result of the ID matching, the ID matching circuit wakes a data communication module.

A. ID Matching Operation

We propose a Bloom-filter-based ID matching mechanism to satisfy the requirements described in Section II-B. A Bloom filter is a simple space-efficient hash coding for representing a set of messages. Allowing some false positives, the Bloom filter gives us a simple membership query method, while rejecting false negatives. The Bloom-filter-based ID matching mechanism can therefore be implemented using a simple circuit.

Figure 2 shows an overview of the Bloom-filter-based ID matching. We use group IDs to specify wake-up target nodes

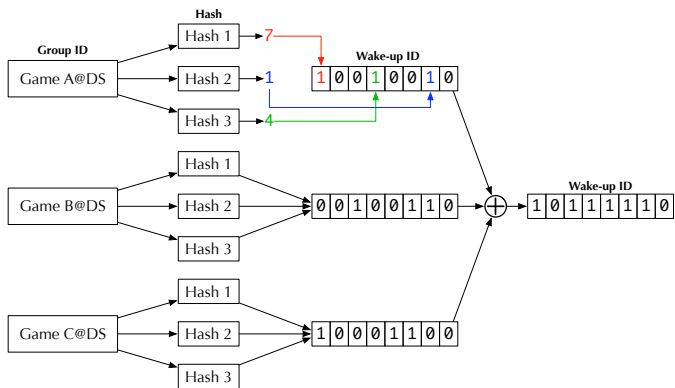

Fig. 3. Process of creating a wake-up ID.

and use wake-up IDs for ID matching. We assume that the group IDs are uniquely assigned to each group in the entire wake-up wireless communication system. The wake-up ID is a Bloom filter, namely, a hash code converted from a set of group IDs. The creation process of the wake-up ID is described in the following section. A receiver node creates a wake-up ID from a set of group IDs that represent the wake-up conditions of the receiver node. The wake-up ID is registered in a wake-up module in the receiver node. A transmitter node creates a wake-up ID from a group ID that is assigned to a wake-up target group. The transmitter then transmits a wake-up packet including this wake-up ID. These two wake-up IDs created by the receiver and the transmitter are used for the ID matching.

The ID matching is performed by only a logical AND operation for two wake-up IDs. The wake-up condition is defined as follows:

$$\begin{aligned} ID_R \cdot ID_T &= ID_T \\ \Rightarrow \overline{ID_R} \cdot ID_T &= 0, \end{aligned} \quad (1)$$

where ID_R is a wake-up ID registered in the receiver node, ID_T is a wake-up ID transmitted by the transmitter node. The receiver node stores an inverted wake-up ID $\overline{ID_R}$. When receiving a wake-up packet, an ID matching circuit in the receiver node calculates logical AND between $\overline{ID_R}$ and ID_T . The ID matching circuit decides to wake up when the AND operation result is 0 or decides not to wake up when the result is not 0. In this scheme, we can realize group selectivity as well as a multiple group support because ID_R includes multiple group IDs. The group selective wake-up as well as the multiple group support can also be realized using multiple registers storing multiple group IDs. Nevertheless, the circuit becomes bigger as the number of IDs increases.

B. Creation of the Wake-up ID

Figure 3 shows the process of creating a wake-up ID using an example of chance encounter communication between handheld game consoles. We assume that there are three games: *Game A*, *Game B*, and *Game C*. As shown in Fig. 3, group IDs are assigned to each game as “Game A@DS,” “Game B@DS,” and “Game C@DS,” respectively.

First, we create wake-up IDs from each group ID. *Game A*’s group ID “Game A@DS” is fed to three hash functions, and we obtain three bit positions: 7, 1, and 4. These three hash functions are globally defined in the entire wake-up wireless

TABLE I
PHYSICAL LAYER PARAMETERS OF THE WAKE-UP CHANNEL.

| | |
|----------------|-----------------|
| Frequency band | 950 MHz band |
| Modulation | 90% ASK |
| Code | Manchester code |
| Baud rate | 40 kBaud |

communication system. These three bit positions in the wake-up ID are set to 1, and other bits are set to 0. The wake-up ID representing a group ID “Game A@DS” is thus 10010010. In the same manner as for *Game A*, we can obtain wake-up IDs 00100110 and 10001100 for *Game B* and *Game C*, respectively.

Next, we create a wake-up ID including multiple group IDs. A wake-up ID containing a set of group IDs is derived by performing a logical OR operation for all wake-up IDs. We therefore obtain the wake-up ID 10111110, which includes three group IDs: “Game A@DS,” “Game B@DS,” and “Game C@DS.”

C. False Positive Wake-ups

Bloom-filter-based ID matching allows some false positives, but rejects false negatives. Considering again the example shown in Fig. 3, we assume that there is another *Game D*, the wake-up ID of which is 10101000. The wake-up ID of a receiver node that supports *Game A*, *Game B*, and *Game C* is 10111110, these two wake-up IDs satisfy Equation (1). The node supporting three games is thus mistakenly woken by a wake-up packet specifying *Game D*.

The probability of false positives can be calculated from the number of group IDs and the length of the wake-up ID in a receiver node. We assume that the number of group IDs is five and the wake-up ID length is 128 bits. Based on the characteristics of Bloom filters, in this case, the false positive probability is minimized when the number of hash functions is 18 and is expressed as

$$p = (1 - e^{-kn/m})^k = 4.6 \times 10^{-6}, \quad (2)$$

where n is the number of group IDs, m is the wake-up ID length, and k is the number of hash functions [8]. When receiving 10 wake-up packets per second, the receiver node receives 864,000 packets per day. In this case, the probability expressed by Equation (2) is equivalent to only four times per day. The false positive probability increases as the number of group IDs increases. We can reduce the false positive probability by using longer wake-up IDs. However, this increases the power consumption and the circuit size.

IV. CIRCUIT AND CHIP LAYOUT DESIGN

A. Circuit Design

We designed our wake-up module circuit to show the feasibility of our wake-up wireless communication system and to evaluate the initial performance of the wake-up system. We referred to existing hardware technologies such as [9][10][11][12] for this design.

TABLE I shows the physical layer parameters of the wake-up channel. We use a 950 MHz UHF band due to its relatively low propagation loss, which we expect to enable longer range communication than the use of other frequency bands at the same transmission power. We choose an ASK

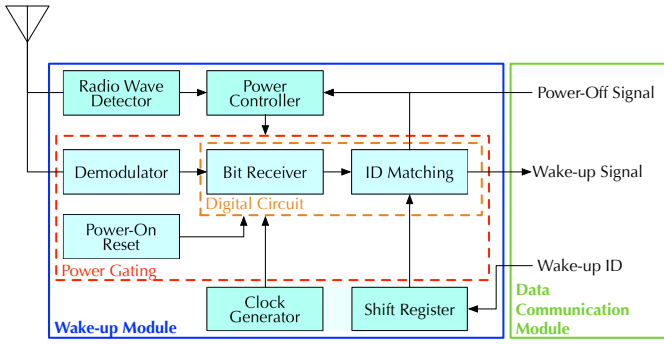

Fig. 4. Block diagram of the wake-up module.

modulation in order to simplify the demodulator circuit and reduce power consumption. Wake-up packets are encoded in Manchester code, which can be decoded without a high-power consumption, high-accuracy clock generator. Since the wake-up module does not need to send much data, the wake-up module communicates at 40 kBaud, which is the same rate as IEEE 802.15.4 in the 915-MHz band [13].

Figure 4 shows a block diagram of the proposed wake-up module. The wake-up module consists of an analog circuit and a digital circuit. The operation of the wake-up module is as follows. (1) A wake-up ID, which represents the wake-up conditions, is registered to a shift register in the wake-up module before use. (2) In an idle listening state, the wake-up module senses radio waves using a radio wave detector and turns off power-gated blocks via a power controller. Note that a clock generator stops oscillation rather than being turned off in the idle listening state, which can suppress an in-rush current. The reduction of the in-rush current enables the use of a smaller MOSFET for power-gating, which reduces the leakage current.

When a transmitter transmits a wake-up packet, (3) the radio wave detector detects its radio waves and turns on the power-gated blocks: a demodulator, a bit receiver, an ID matching circuit, and a power-on reset circuit. (4) The demodulator demodulates the wake-up packet and the bit receiver decodes the wake-up packet, extracting and storing the wake-up ID inside. After receiving the wake-up packet, (5) the ID matching circuit performs ID matching according to the operation described in Section III-A. If two wake-up IDs match, then the ID matching circuit asserts a wake-up signal that wakes a data communication module. (6) The data communication module begins communication with the transmitter and asserts a power-off signal, letting the wake-up module return to the idle listening state. (7) The data communication module reenters the sleep state after communication. (5') If two wake-up IDs do not match, then the ID matching circuit immediately asserts a power-off signal and the wake-up module returns to the idle listening state.

Figure 5 shows an analog circuit of the wake-up module. The number of MOSFETs in each analog circuit block is 29 for a radio wave detector, 19 for a demodulator, 20 for a power controller, 14 for a clock generator, and five for a power-on reset circuit. The radio wave detector is a Dickson charge pump [9] and is composed of a stack of seven units based on preliminary simulation results. The output of the

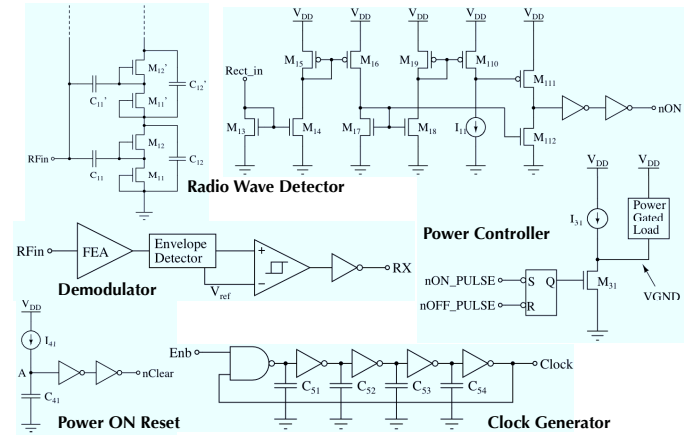

Fig. 5. An analog circuit of the wake-up module.

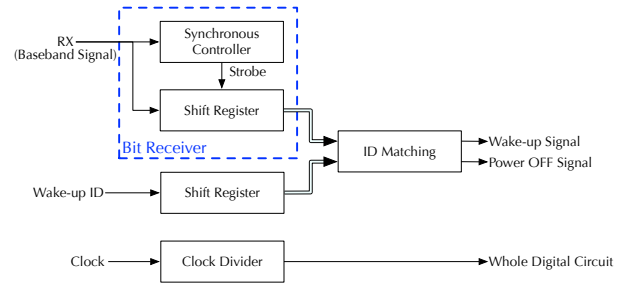

Fig. 6. A digital circuit of the wake-up module.

charge pump is connected to a voltage level converter that converts the voltage to the CMOS level. The demodulator consists of a front-end amplifier, an envelope detector, a Schmitt comparator, and an inverter. The power controller uses a power-gating NMOS and a set-reset flip-flop. In order to reduce the turn-off time, a current source is connected to the drain terminal of the power-gating NMOS. The power-on reset circuit consists of a delay element and a buffer. The clock generator is a five-stage CMOS ring oscillator. In order to control its oscillation, the first stage uses a NAND gate.

Figure 6 shows a digital circuit of the wake-up module. The digital circuit consists of five blocks: a clock divider, a synchronous controller, two shift registers, and an ID matching circuit. The digital circuit is designed using Verilog HDL [14]. A clock divider divides an incoming clock by a factor of two and globally distributes the divided clock to the entire digital circuit, which reduces the power consumption of the digital circuit. As described in the previous section, a wake-up ID must be set into the shift register before using the wake-up module. When the digital circuit is woken, a synchronous controller synchronizes with wake-up packet bits while receiving the header and then generates strobe signals for each bit. A shift register in a bit receiver stores the wake-up ID using these strobe signals. After storing the wake-up ID, an ID matching circuit performs ID matching using two wake-up IDs stored in the two shift registers and asserts a wake-up signal or a power-off signal.

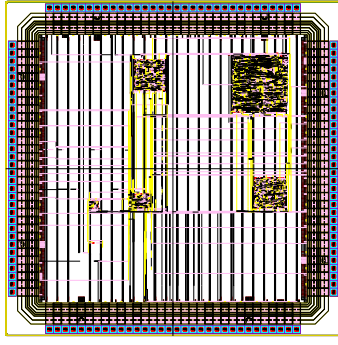

Fig. 7. Chip layout of the digital circuit.

TABLE II
EVALUATION OF THE ANALOG CIRCUIT.

| | | |
|---------------------------------|----------------------------|---------------|
| Power consumption | Idle listening | 12.4 μ W |
| | Receiving a wake-up packet | 310.3 μ W |
| Clock frequency | | 855 kHz |
| Radio wave detector sensitivity | | -36.9 dBm |

B. Chip Layout Design

In order to evaluate the circuit area size as well as the power consumption, we designed the chip layout of the digital circuit using a 0.18- μ m triple-well single-poly five-metal CMOS process with a 1.8-V supply voltage. Figure 7 shows the chip layout of the digital circuit. The digital circuit is synthesized with the Design Compiler [15] and is placed and routed with Astro [16]. We choose a 0.18- μ m CMOS process because of its wide availability and low-cost fabrication. Note that the leakage current of the 0.18- μ m CMOS process is lower than that of smaller CMOS processes.

For the purpose of comparison with the proposed Bloom-filter-based ID matching, we also designed another ID matching circuit, which stores and performs ID matching with multiple group IDs. We designed seven circuit layouts, which have different numbers of registers: 1, 2, 3, 4, 5, 10, and 20.

V. EVALUATION

In order to evaluate the listening power consumption of the proposed wake-up wireless communication system, we first evaluate the wake-up module designed in the previous section by performing circuit-level simulations. The analog circuit and the digital circuit are evaluated separately because they are designed separately. We then evaluate the listening power consumption of the wake-up wireless communication system.

A. Wake-up Module

For the analog circuit, we evaluate the power consumption, the clock frequency, and the radio wave detector sensitivity. The analog circuit is evaluated by performing simulations using HSPICE [17]. We use BPTM 180 nm [18] as a MOSFET model and use ideal resistor, capacitor, and inductor models.

TABLE II shows the results of the evaluation of the analog circuit. In an idle listening state, the wake-up module consumes only 12.4 μ W. The listening power consumption of the proposed wake-up module is thus approximately the same as that of a self-discharge from a 1,000 mAh Ni-MH battery. The clock frequency, which we assume to be supplied to the digital circuit, is 855 kHz. Based on the sensitivity, the

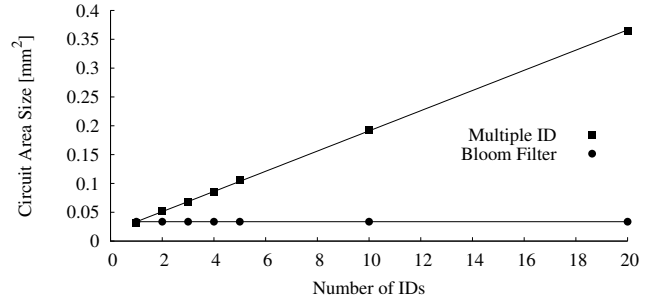

Fig. 8. Circuit area size of the digital circuit.

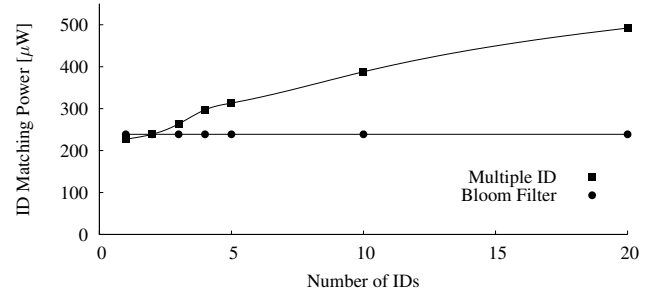

Fig. 9. Power consumption of the digital circuit.

maximum transmission range is estimated at 3.9 m using the Friis equation, where the transmission power is 10 mW, and the transmitter/receiver antenna gains are 0 dBi. We believe that this range can be extended to 10 m if we apply lower-power hardware techniques, such as those of [19][20][21][22].

For the digital circuit, we evaluate the circuit area size and power consumption. We derive the circuit area size from the chip layout, i.e., the place&route result. The power consumption is derived from a circuit-level simulation. We first derive a SPICE netlist from the chip layout, and then perform simulations with HSIM [23].

Figure 8 shows the circuit area size, and Fig. 9 shows the power consumption of the digital circuit. The proposed circuit occupies an area of 33,665 μ m², whereas a conventional single-ID circuit occupies an area of 31,194 μ m². The power consumption of the proposed circuit is 238.8 μ W, whereas the conventional single-ID circuit consumes 227.8 μ W. Therefore, the circuit area size and power consumption of the proposed circuit are approximately the same as those of the conventional single-ID circuit. As the number of IDs increases, the area and power consumption of the conventional circuit increase continuously, whereas those of the proposed circuit remain constant.

B. Wake-up Wireless Communication System

We evaluate the reduction in energy realized by the proposed wake-up system as compared to a system without a wake-up mechanism and a system with a wake-up but without group selectivity. We assume that the data communication module is IEEE 802.11g WLRG-RA-DP101 [24], which consumes 907.5 mW when receiving data. We also assume that each node has a 128-bit length wake-up ID, which includes five group IDs. For the proposed wake-up system, we consider that false

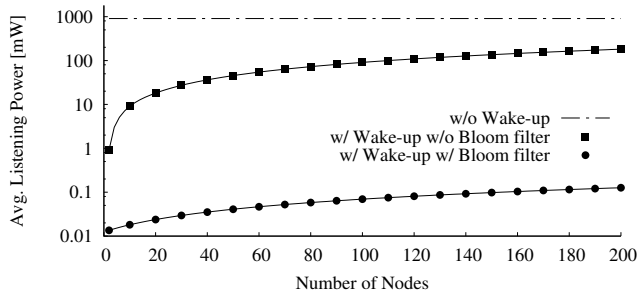

Fig. 10. Average listening power as a function of the number of nodes.

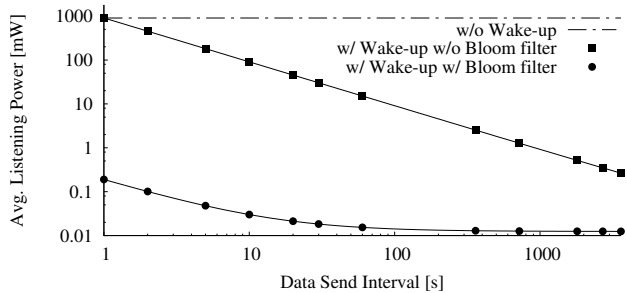

Fig. 11. Average listening power as a function of the data send interval.

positive wake-ups occur, as described in Section III-C, and the node goes to a sleep state after 10 milliseconds when woken up unnecessarily.

Figures 10 and 11 show the average listening power of the proposed wake-up wireless communication system as a function of the number of nodes and the data send interval, respectively. The plot “with wake-up without Bloom filter” indicates that the system uses a wake-up scheme but that no group selectivity is available. The transmitter must wake-up all nodes when communicating with multiple nodes. In Fig. 10, we assume that each node transmits a wake-up packet every 10 seconds, and in Fig. 11, we assume that the number of nodes is 100. Note that we ignore the power consumption during data communication because the proposed wake-up system has no effect on the power consumption during this time.

As shown in Fig. 10, the proposed group selective wake-up mechanism can effectively reduce listening power. The proposed wake-up system reduces listening power by a factor of 1,000 to 10,000, as compared to the system without a wake-up mechanism. In comparison with another wake-up scheme, the proposed system can also reduce listening power by a factor of 100 to 1,000. This is because the wake-up packet increases as the number of nodes increases, which implies that the number of unnecessary wake-ups increases in the other wake-up scheme.

As shown in Fig. 11, the proposed wake-up system effectively reduces the listening power for the short data send interval. The proposed system can still reduce the power by a factor of 20 when the data send interval is as long as 3,600 seconds, although the amount of power reduction becomes smaller as the interval increases.

VI. CONCLUSION

In the present paper, we have proposed a wake-up wireless communication system with a Bloom-filter-based ID matching mechanism, which effectively reduces listening power consumption. We are currently working on the fabrication of a wake-up module that includes analog circuits.

ACKNOWLEDGMENT

The present study is supported by Core Research for Evolutional Science and Technology (CREST) and the VLSI Design and Education Center (VDEC) at the University of Tokyo, in collaboration with Cadence Design Systems, Inc. and Synopsys, Inc.

REFERENCES

- [1] G. Retz *et al.*, “A highly integrated low-power 2.4GHz transceiver using a direct-conversion diversity receiver in 0.18 μm CMOS for IEEE 802.15.4 WPAN,” in *IEEE Int. Solid-State Circuits Conf. (ISSCC) Dig. Tech. Papers*, Feb. 2009, pp. 414–415, 415a.
- [2] R. van Langevelde *et al.*, “An ultra-low-power 868/915 MHz RF transceiver for wireless sensor network applications,” in *Proc. IEEE Radio Freq. Integr. Circuits Symp. (RFIC)*, Jun. 2009, pp. 113–116.
- [3] W. Ye, J. Heidemann, and D. Estrin, “An energy-efficient MAC protocol for wireless sensor networks,” in *Proc. Annual Joint Conf. IEEE Comput. Commun. Soc.*, vol. 3, Jun. 2002, pp. 1567–1576.
- [4] J. Polastre, J. Hill, and D. Culler, “Versatile low power media access for wireless sensor networks,” in *Proc. ACM Conf. Embedded Netw. Sensor Syst. (SenSys)*, Nov. 2004, pp. 95–107.
- [5] T. van Dam and K. Langendoen, “An adaptive energy-efficient MAC protocol for wireless sensor,” in *Proc. ACM Conf. Embedded Netw. Sensor Syst. (SenSys)*, Nov. 2003, pp. 171–180.
- [6] P. Dutta and D. Culler, “Practical asynchronous neighbor discovery and rendezvous for mobile sensing applications,” in *Proc. ACM Conf. Embedded Netw. Sensor Syst. (SenSys)*, Nov. 2008, pp. 71–83.
- [7] B. H. Bloom, “Space/time trade-offs in hash coding with allowable errors,” *Commun. ACM*, pp. 422–426, Jul. 1970.
- [8] A. Broder and M. Mitzenmacher, “Network applications of bloom filters: A survey,” *J. Internet Math.*, vol. 1, no. 4, pp. 485–509, Apr. 2003.
- [9] J. F. Dickson, “On-chip high-voltage generation in MNOS integrated circuits using an improved voltage multiplier technique,” *IEEE J. Solid-State Circuits*, vol. SC-11, no. 3, pp. 347–378, Jun. 1976.
- [10] N. Pletcher, S. Gambini, and J. Rabaey, “A 65 μW , 1.9GHz RF to digital baseband wakeup receiver for wireless sensor nodes,” in *Proc. IEEE Custom Integr. Circuits Conf. (CICC)*, Oct. 2007, pp. 539–542.
- [11] R. G. Meyer, “Low-power monolithic RF peak detector analysis,” *IEEE J. Solid-State Circuits*, vol. 30, no. 1, Jan. 1995.
- [12] H. W. Chen and W. C. Yen, “A low power and fast wake up circuit,” in *Proc. IEEE Int. Symp. Circuits Syst. (ISCAS)*, vol. 2, May 2004, pp. II-293–II-296.
- [13] “IEEE standard for local and metropolitan area networks: Part 15.4 (IEEE 802.15.4-2003).”
- [14] “IEEE standard for Verilog Hardware Description Language (IEEE 1364-2005).”
- [15] Synopsys, “Design Compiler Ultra.”
- [16] Synopsys, “Astro.”
- [17] Synopsys, “HSPICE: The gold standard for accurate circuit simulation.”
- [18] UC Berkeley, “Berkeley predictive technology model,” <http://www.eas.asu.edu/~ptm/>.
- [19] N. M. Pletcher, G. Gambini, and J. M. Rabaey, “A 2 GHz 52 μW wake-up receiver with -72 dBm sensitivity using uncertain-IF architecture,” in *IEEE Int. Solid-State Circuits Conf. (ISSCC) Dig. Tech. Papers*, Feb. 2008, pp. 524–525, 633.
- [20] T. Umeda *et al.*, “A 950-MHz rectifier circuit for sensor network tags with 10-m distance,” *IEEE J. Solid-State Circuits*, vol. 41, no. 1, pp. 35–41, Jan. 2006.
- [21] T. Umeda and S. Otaka, “ECO chip: Energy consumption zeroize chip with a 953 MHz high-sensitivity radio wave detector for standby mode applications,” in *Proc. IEEE Custom Integr. Circuits Conf. (CICC)*, Oct. 2007, pp. 663–666.
- [22] M. S. Durante and S. Mahlkecht, “An ultra low power wakeup receiver for wireless sensor nodes,” in *Proc. Int. Conf. Sensor Technol. Appl.*, Jun. 2009, pp. 167–170.
- [23] Synopsys, “HSIM: Hierarchical full-chip circuit simulation and analysis.”
- [24] QUATECH, “Airborne 802.11 embedded radio modules,” http://www.dpactech.com/docs/wireless_products/ab_radio.pdf.